

Mikropor water separators have been designed for the removal of bulk liquid water and particulate from compressed air and gases. Unique centrifugal action removes contaminants at low-pressure drop for maximum energy saving.

Mikropor water separators are available from 1/4" - 3" pipe sizes and for flows up to 2200 m<sup>3</sup>/h (1294 cfm).

**Note:** While highly efficient, condensate separators will not remove 100% of the oil from the air stream. Additional coalescing and particulate filters downstream may be required to remove the fine traces of oil, water and particles.

**Note:** Automatic drain valves are fitted as standard. All separator bodies are coated with electrostatic powder paint finish both inside and out.

## Correction Factor

For maximum flow rate, multiply model flow rate show in the above table by the correction factor corresponding to the working pressure.

Operating Pressure (bar)	Psi	Correction Factor
1	15	0.5
3	44	0.71
5	73	0.87
7	100	1
9	131	1.12
11	160	1.22
13	189	1.32
15	218	1.44
16	247	1.57



## Technical Specifications

For maximum flow rate, multiply model flow rate show in the above table by the correction factor corresponding to the working pressure.

Model	Connection Size	Flow Rate		Housing Dimensions (mm)			
		(m <sup>3</sup> /h)	(cfm)	A	B	C	D
G25WS	1/4"	25	14	103	257.5	236	160
G100WS	1/2"	100	58	103	257.5	236	210
G200WS	3/4"	200	117	123	304	277	285
G300WS	1"	300	176	123	304	277	380
G600WS	1 1/2"	600	353	123	320	285	470
G1200WS	2"	1200	706	160	484	443	560
G2200WS	3"	2200	1294	193	546	490	610

Max. Recommended Operating Temperature	Min. Recommended Operating Temperature	Typical Pressure Loss at Rated Flow	Max. Working Pressure
80°C	1.5°C	50 mbar	16 bar

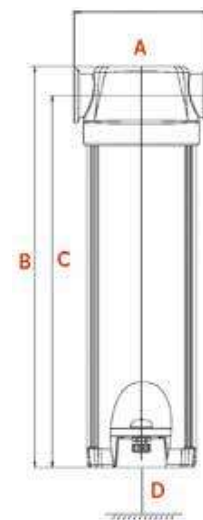

# ▶ FLANGED COMPRESSED WATER SEPARATORS

Mikropor flanged water separators have been designed for the removal of bulk liquid water and particulate from compressed air and gases. Unique centrifugal action removes contaminants at low-pressure drop for maximum energy savings. Mikropor flanged water separators are available from DN80–DN200 flange sizes and flows up to 14000 m<sup>3</sup>/h (8236 cfm) **(For larger sizes please contact our sales team).**

**Note:** While highly efficient, condensate separators will not remove all of the oil from the air stream. Additional coalescing and particulate filters downstream may be required to remove the fine traces of oil, water and particles.

## Correction Factor

For maximum flow rates, multiply model flow rate show in the above table by the correction factor corresponding to the working pressure.

Operating Pressure (bar)	PSI	Correction Factor
1	15	0.5
3	44	0.71
5	73	0.87
7	100	1
9	131	1.12
11	160	1.22
13	189	1.32
14	200	1.38

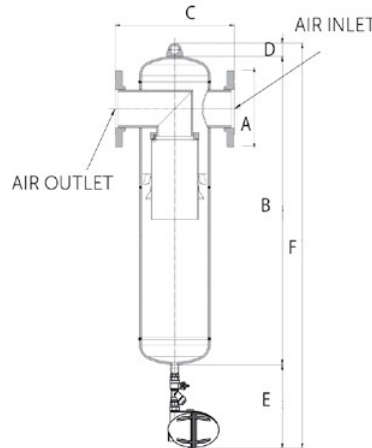

Max. Recommended Operating Temperature	Min. Recommended Operating Temperature	Typical Pressure Loss at Rated Flow	Max. Working Pressure
80°C	1.5°C	50 mbar	14 bar

## Technical Specifications

Model	Connection Size	Flow Rate		Housing Dimensions (mm)					
		(m <sup>3</sup> /h)	(cfm)	A	B	C	D	E	F
F-2500WS	DN80	2500	1407.5	200	934	450	75	280	1289
F-3200WS	DN100	3200	1882.3	220	964	450	75	280	1319
F-4300WS	DN100	4300	2529.4	220	982	530	75	280	1283
F-6500WS	DN150	6500	3823.5	285	1092	580	75	280	1447
F-8500WS	DN150	8500	5000	285	1091	650	75	280	1446
F-11000WS	DN200	11000	6470.5	340	1168	750	75	280	1523
F-14000WS	DN200	14000	8235.2	340	1201	800	75	280	1556